

TD EVO VAR

DUAL CONTROL IN-LINE DUCT MOUNTED FAN

5*
YEAR WARRANTY

IP44

**EURO
MADE**

**ULTRA
QUIET**

CONTROLLABILITY

The TD EVO VAR in-line fan has been designed to provide highly efficient performance with low energy consumption for domestic and commercial applications. It can be speed controlled via an on-board potentiometer, or remotely via a 0-10V or 4-20mA analogue input signal.

The TD EVO VAR also comes standard with an on-board, adjustable 1 to 30 minute run-on-timer that allows steam and odour to be exhausted after leaving the room.

TD EVO VAR is suitable for toilets, bathrooms, ensuites, laundries and kitchens in homes, hotels, apartments and commercial buildings. There are 6 models in the range matching standard duct sizes from 100 to 315mm diameter.

- Speed controllable via on-board potentiometer or external 0-10V or 4-20mA signal.
- Optimised impeller, guide vanes, and outlet diffuser for low noise operation.
- Main fan body is easily removed without dismantling ducting.
- Highly efficient single-phase AC motor.
- Fan can be mounted in any position.
- Junction box can be rotated to any position.
- Integrated run-on-timer (0, 1, 5, 15 and 30 minutes).

DIMENSIONS

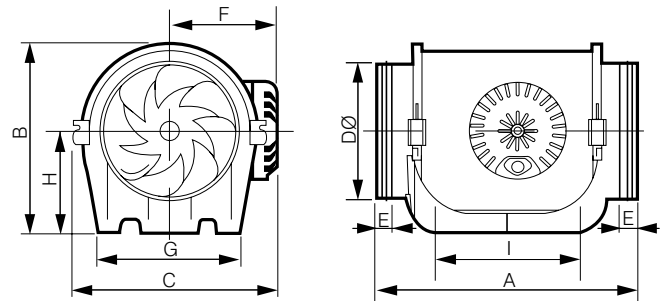

MODEL NO.	A	B	C	DØ	E	F	G	H	WEIGHT KG
TD-EVO-100VAR	302	181	201	97	29	107	133	100	1.7
TD-EVO-125VAR	302	191	221	123	29	117	132	100	1.8
TD-EVO-150VAR	326	221	240	147	25	126	165	120	3.0
TD-EVO-200VAR	346	238	263	197	28	137	190	124	4.1
TD-EVO-250VAR	390	289	306	247	40	159	230	155	6.2
TD-EVO-315VAR	485	353	371	312	40	192	278	188	8.4

All dimensions in mm

SPECIFICATIONS

MODEL NO.	M ³ /HR [†]	L/SEC [†]	FAN SPEED REV/SEC	AVG. dB(A) @ 3M ^{**}	1PH WATTS	AMPS	MAX. AMB °C	VOLTS
TD-EVO-100VAR	210	58	41	31	16	0.1	60	220-240
TD-EVO-125VAR	310	86	39	36	29	0.1	60	220-240
TD-EVO-150VAR	560	156	44	44	45	0.2	60	220-240
TD-EVO-200VAR	900	250	45	47	107	0.5	60	220-240
TD-EVO-250VAR	1400	389	45	52	181	0.8	60	220-240
TD-EVO-315VAR	1840	511	44	56	273	1.1	60	220-240

** Inlet sound levels

† Air flow without duct and fittings

*Conditions apply. For details visit: fantechtrade.com.au/warranty