

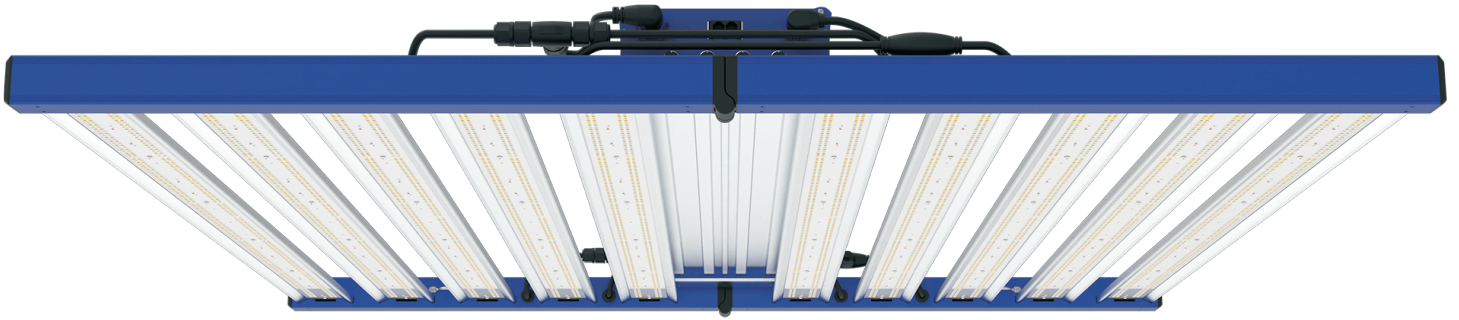

TARANTULA BORG EVOLUTION



Grand Master Leds
www.grandmasterleds.com

TARANTULA BORG EVOLUTION

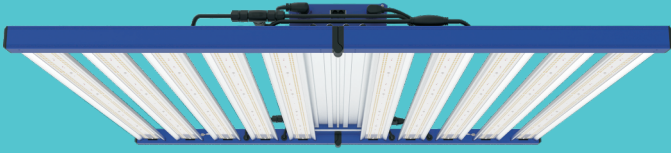

HIGH EFFICIENCY

POWER SAVING

ADJUSTABLE SPECTRUM

TARANTULA BORG EVOLUTION

- Samsung LM301H EVO Mint White + LEDESTAR 2835 White
- Osram 660nm + LEDESTAR 450nm + LEDESTAR 730nm
- INVENTRONICS LED driver
- Knob dimming + RJ port dimming
- Folding design for fast and easy installation
- Adjustable Spectrum
- 5 year warranty
- IP 66 Waterproof
- Input Voltage: 100-277Vac

Specifications

Model Name	Tarantula Borg Evolution		
Input Voltage	120 Vac	240 Vac	277 Vac
Max. Input Current	13.0 Amps	6.6 Amps	5.8 Amps
Power Factor	0.99	0.95	0.95
Wattage +/- 5%	1530W (612W+612W+204W+102W)	1500W (600W+600W+200W+100W)	1500W (600W+600W+200W+100W)
Qty. of Light Bars	10 Bars	10 Bars	10 Bars

LED Driver	Inventronics	Surge Protection	6KV
LED Brand	SAMSUNG & OSRAM	LED Configuration	6500K+9000K+Mint White+450nm & 2200K&660nm&730nm
Dimming	Knob + RJ port	LED life time	>100,000 hours
Dimming	10%~100% DIM-TO-OFF	Power Cord Length	10' (3.05M)
IP Rate	IP 66	Max. Ambient Temp.	104 °F (40 °C)
Warranty	5 Year	Mounting Height	>36" (Above Canopy)

Packaging (Luminaire)		Packaging (Driver)	
Carton Size	124 x 67 x 17cm (48.82" x 26.38" x 6.69")	Carton Size	117 x 25 x 16cm (46.06" x 9.84" x 6.30")
Weight	18.25 kg (40.23 lbs)	Weight	13.25 kg (29.21 lbs)
Qty. / Ctn.	1PC	Qty. / Ctn.	1PC

Details

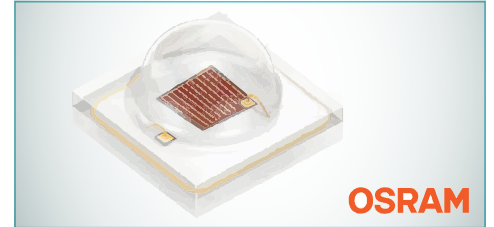
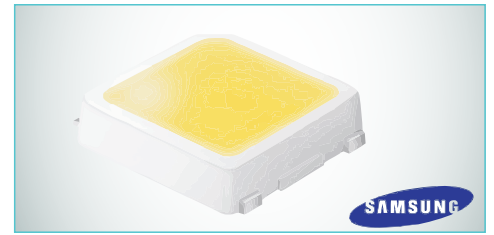

Plug



USA 120Vac (NEMA 5-15P)
Standard

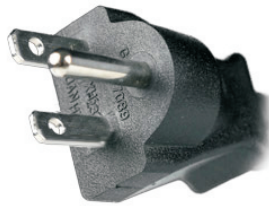

USA 240Vac (NEMA 6-15P)
Optional



USA 277Vac (NEMA 7-15P)
Optional

Dimension & Weight

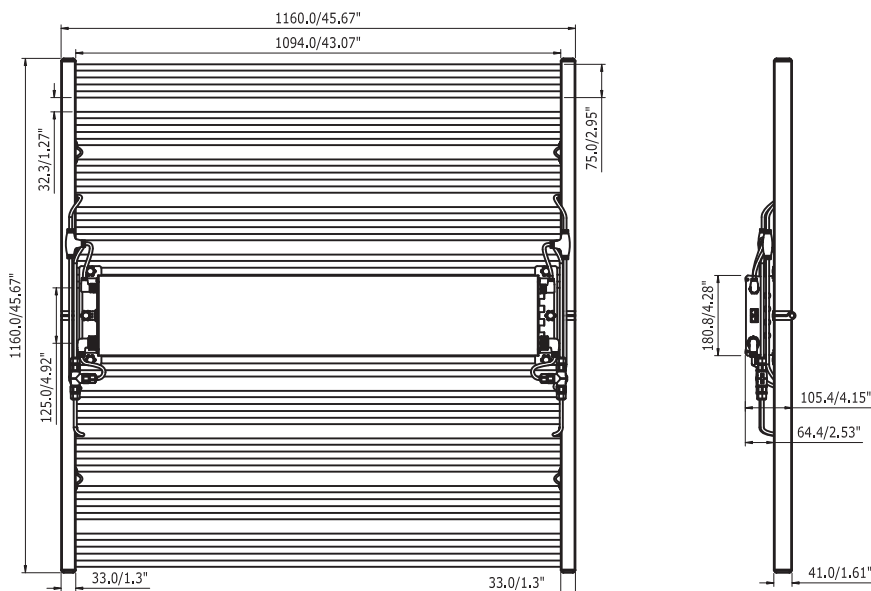

Fixture Dimension:
1160mm X 1160mm X 105.4mm
(45.67" X 45.67" X 4.15")

Fixture Net Weight:
27.85 kg (61.40 lbs) Including Driver box

Knob Dimming + RJ Port dimming 10%~100% DIM-TO-OFF

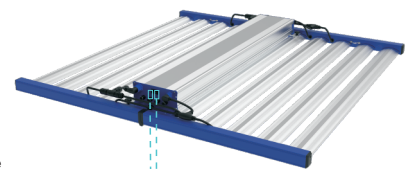
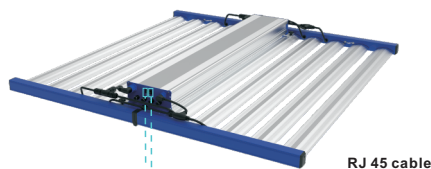
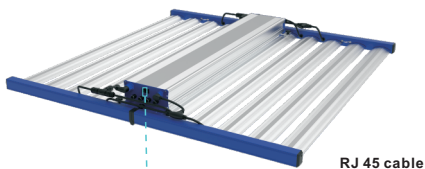
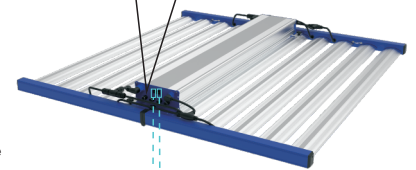
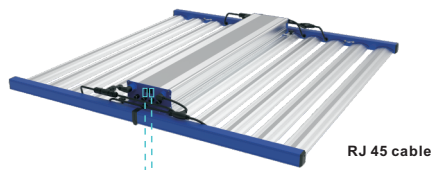
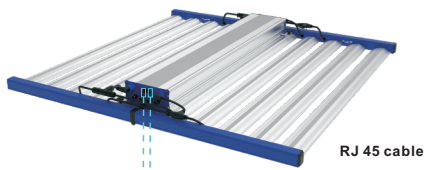
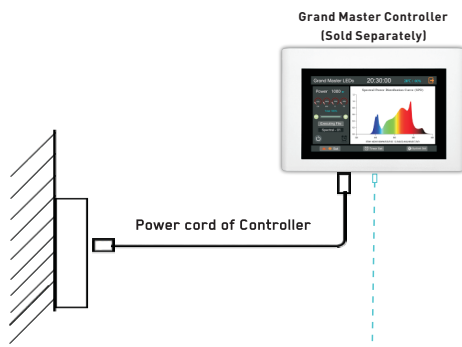

Control Signal input and output

Controller (RJ 45)							
PIN 1	PIN 2	PIN 3	PIN 4	PIN 5	PIN 6	PIN 7	PIN 8
Dim2	N/A	Dim1	GND	GND	Dim4	N/A	Dim3
Fixture (INPUT) Side (RJ 45)							
PIN 1	PIN 2	PIN 3	PIN 4	PIN 5	PIN 6	PIN 7	PIN 8
Dim2	N/A	Dim1	GND	GND	Dim4	N/A	Dim3
Fixture (OUTPUT) Side (RJ 45)							
PIN 1	PIN 2	PIN 3	PIN 4	PIN 5	PIN 6	PIN 7	PIN 8
Dim2	N/A	Dim1	GND	GND	Dim4	N/A	Dim3

Spectrum Possibilities (SPD)

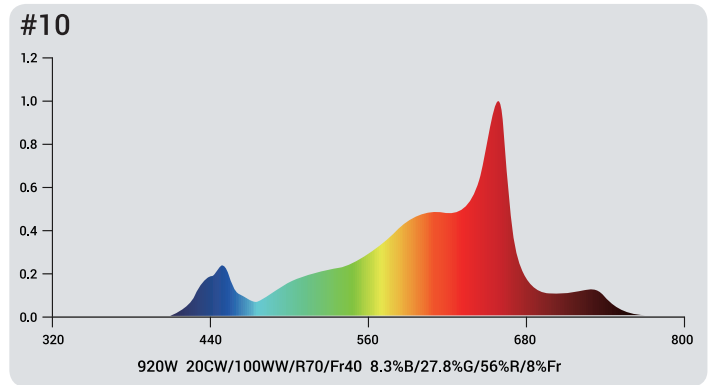
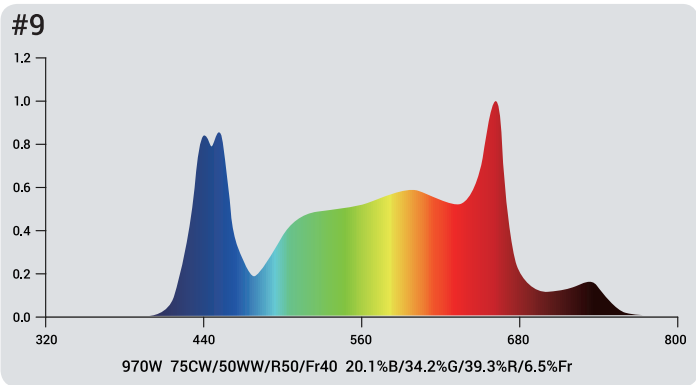
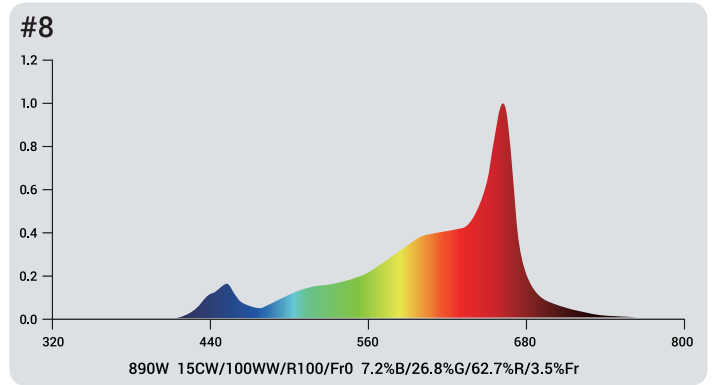
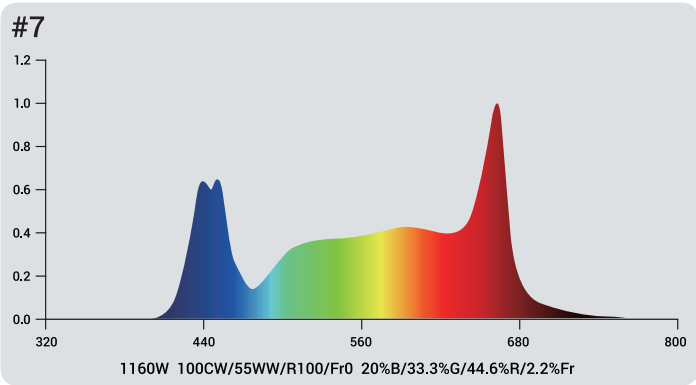
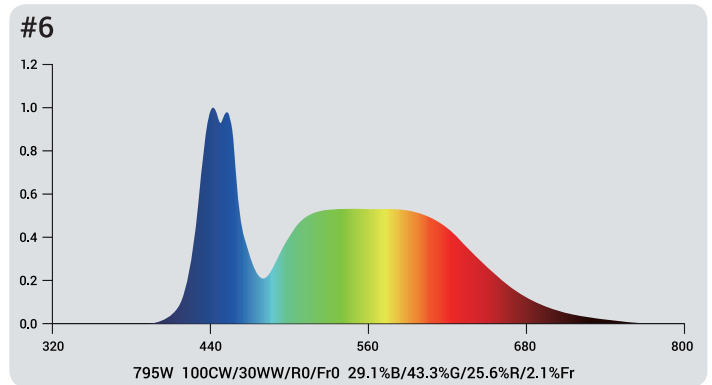
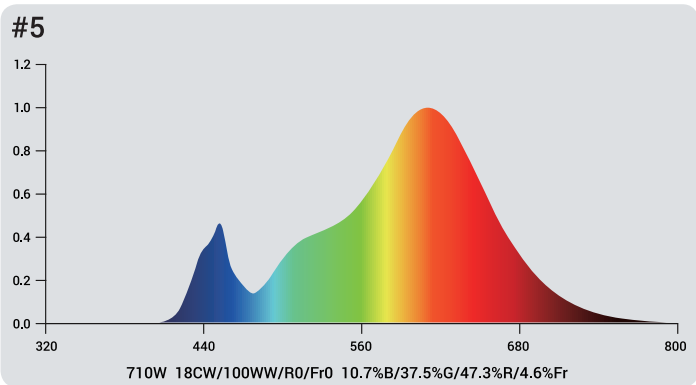
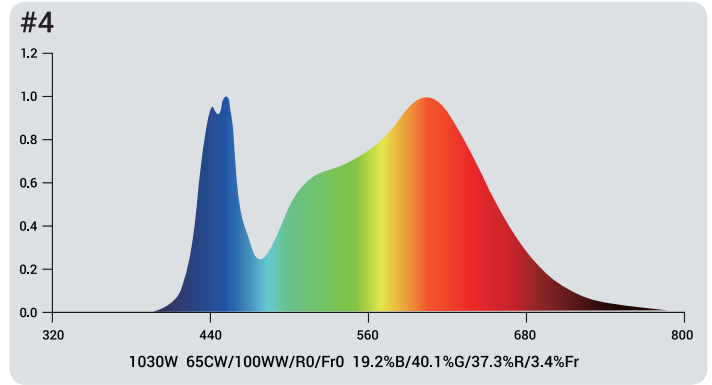
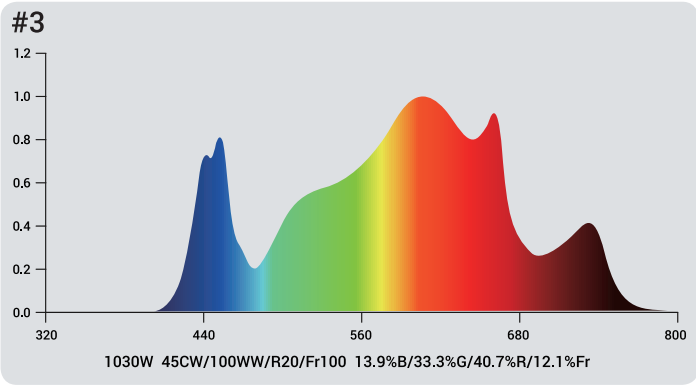
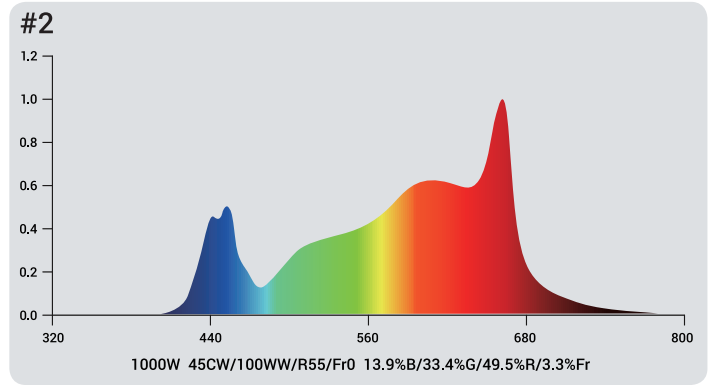
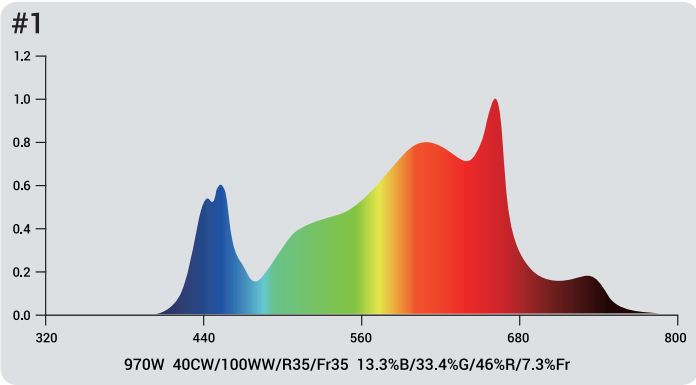

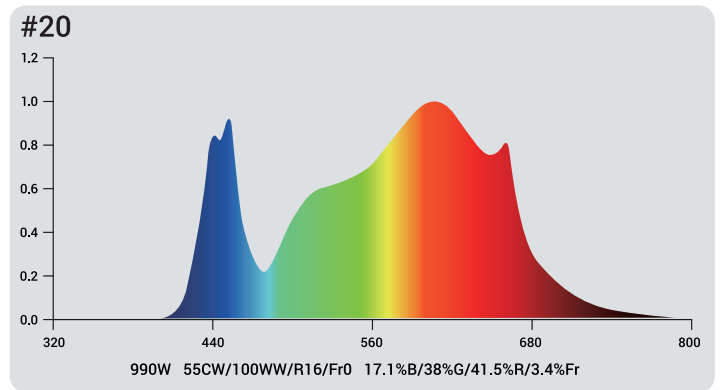
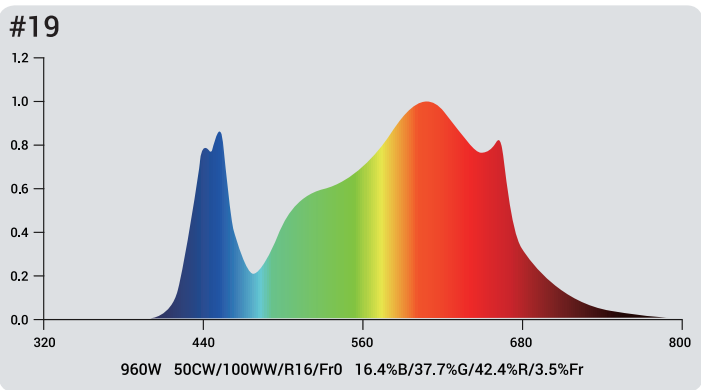
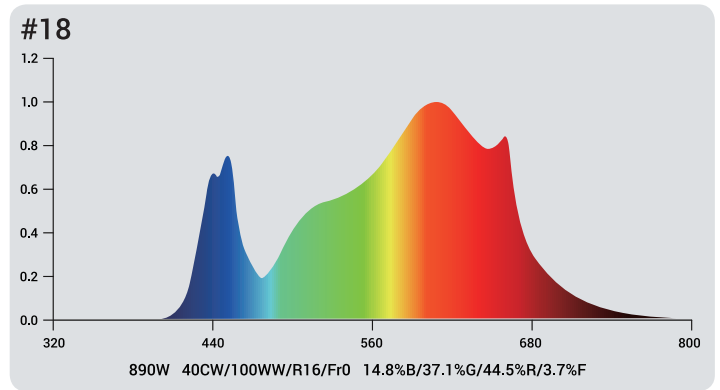
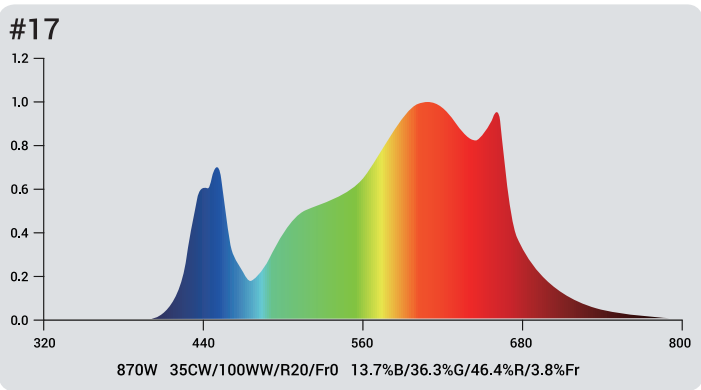
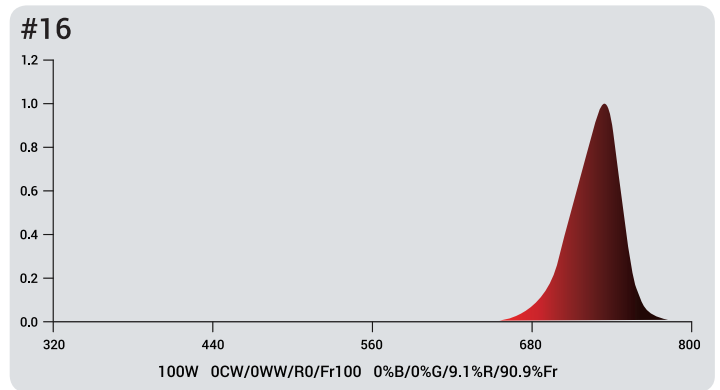
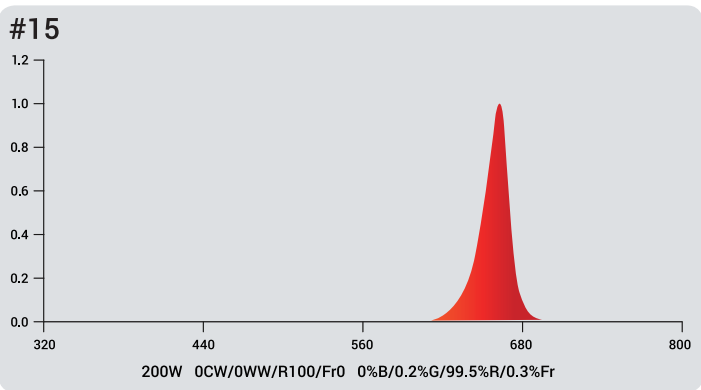
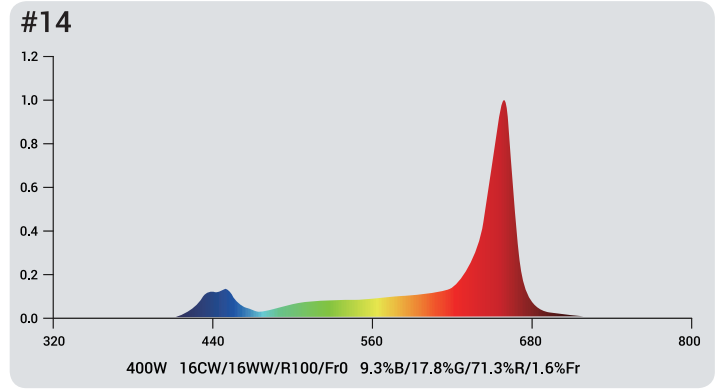
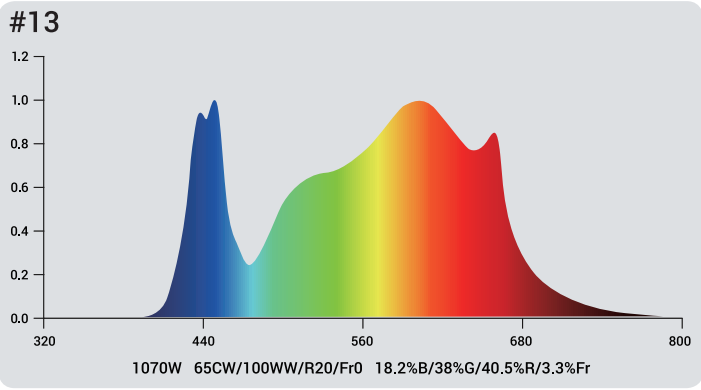
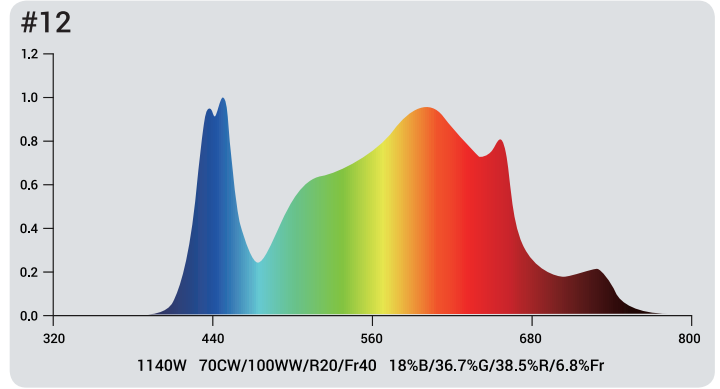
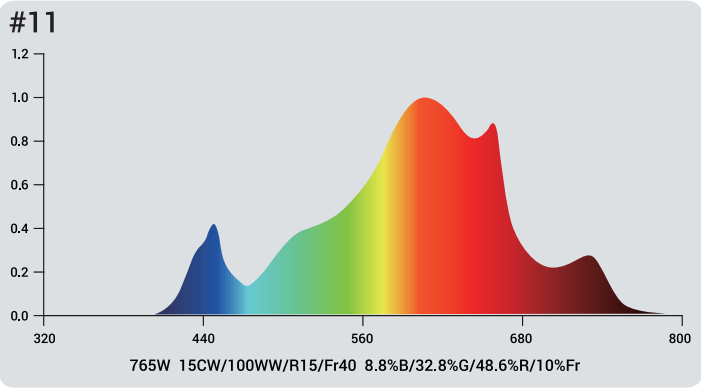

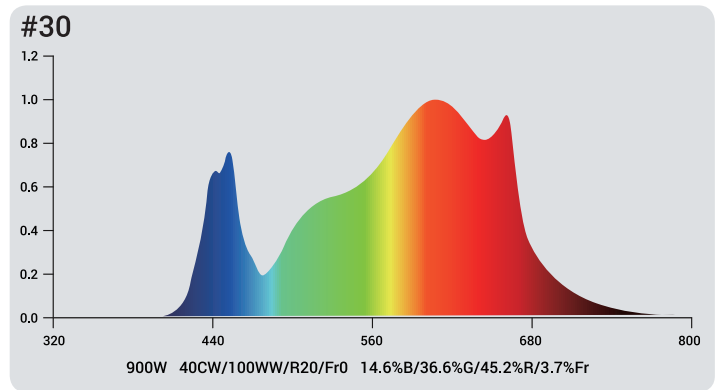
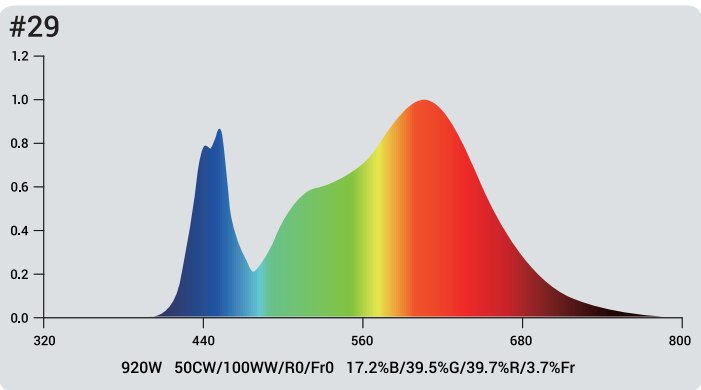
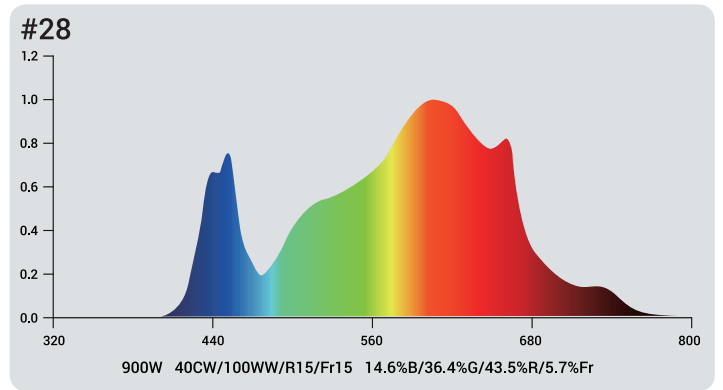
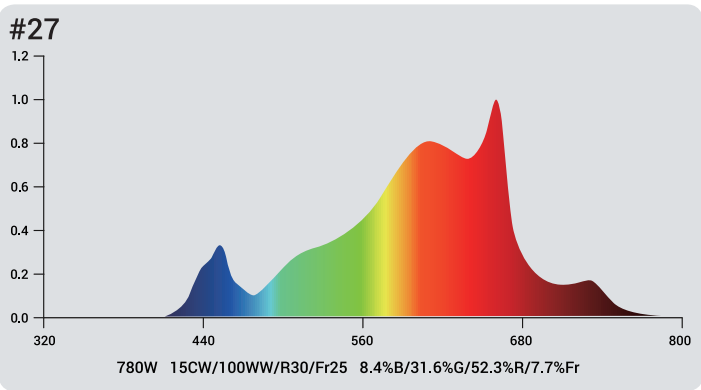
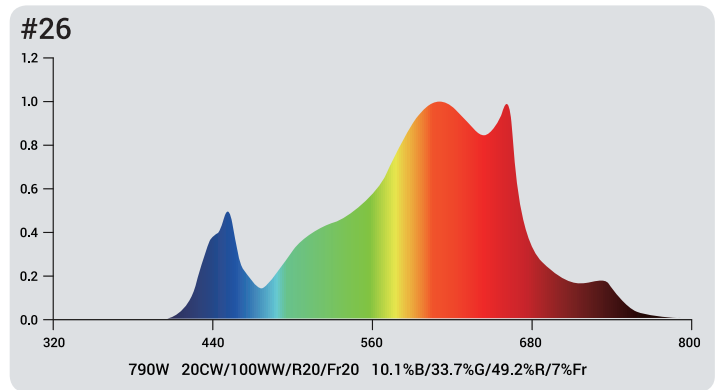
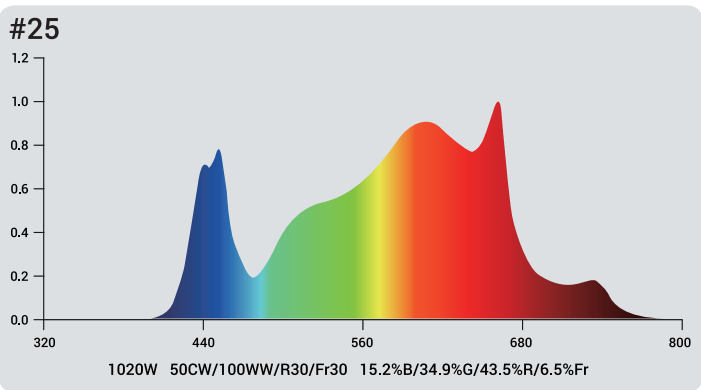
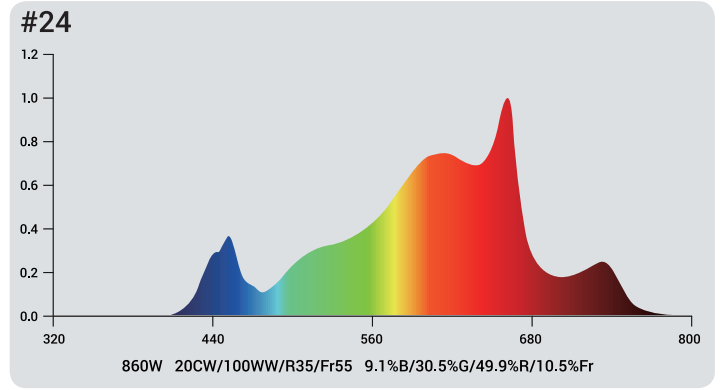
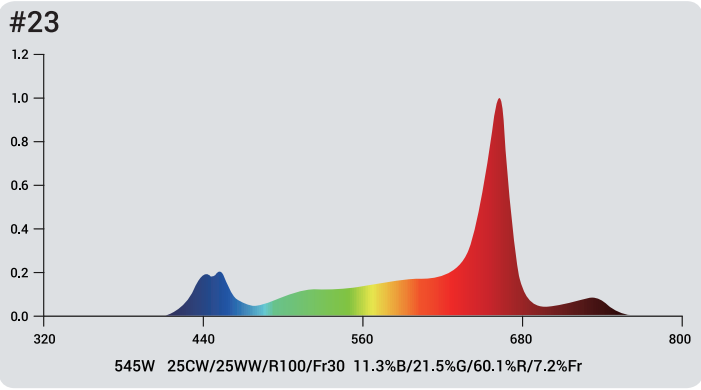
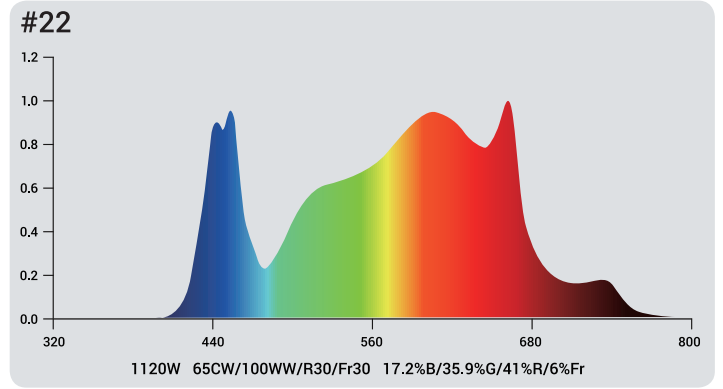
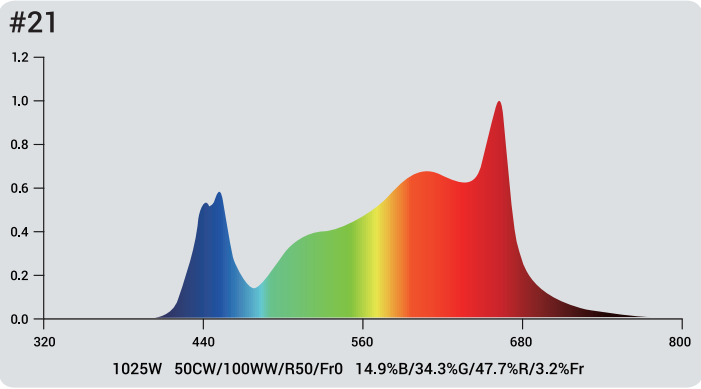

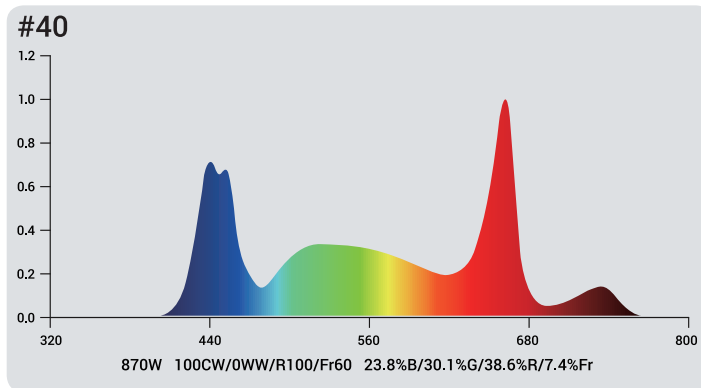
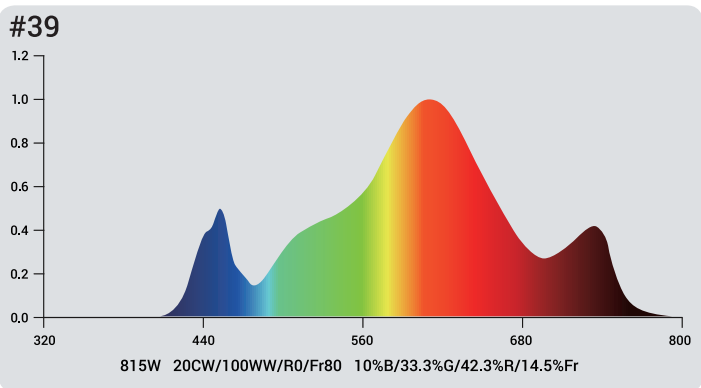
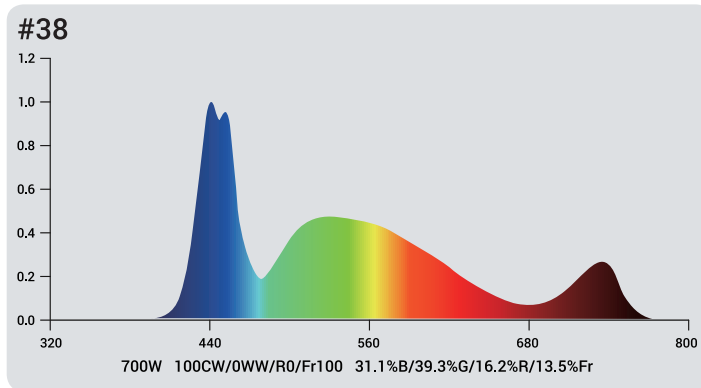
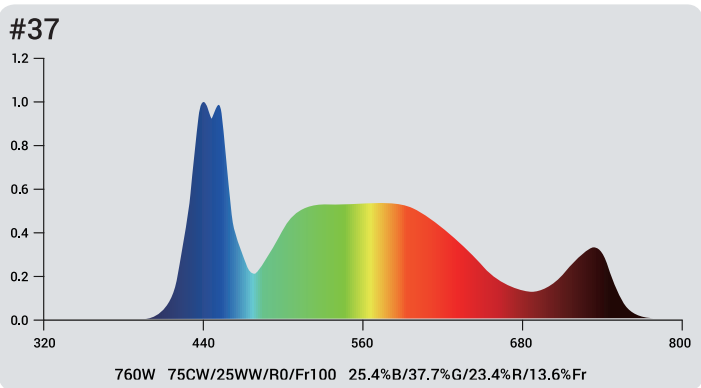
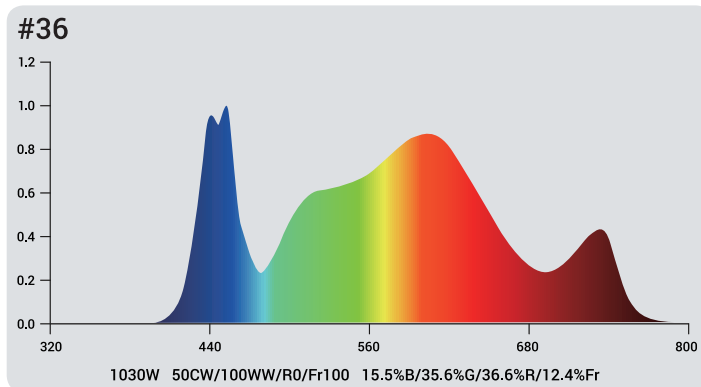
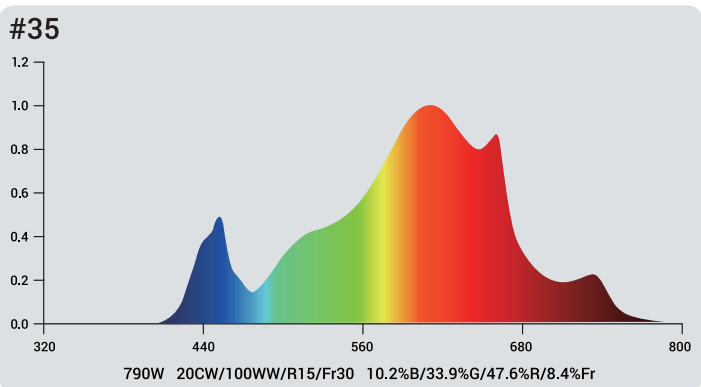
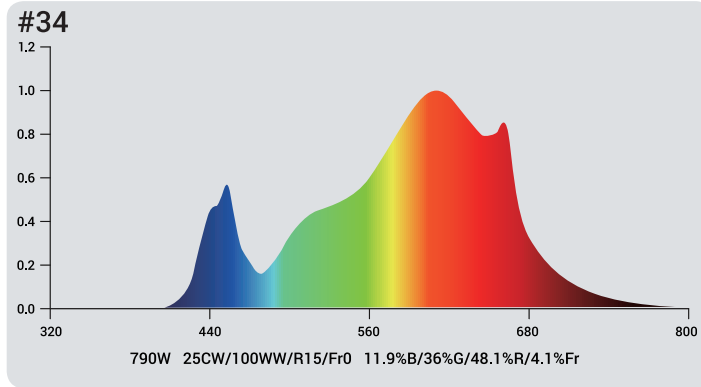
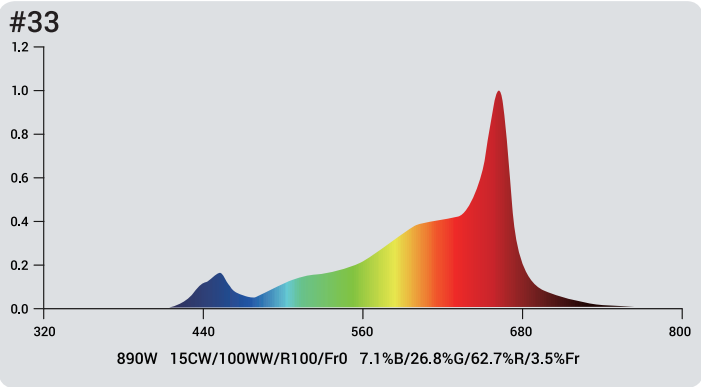
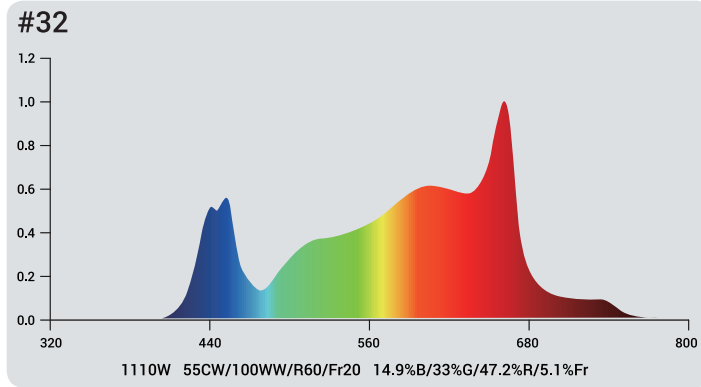
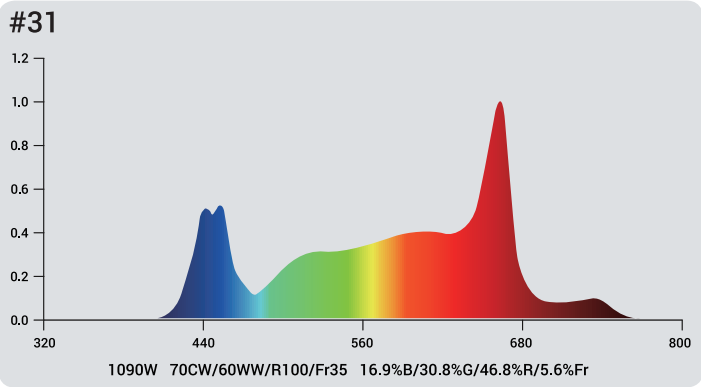

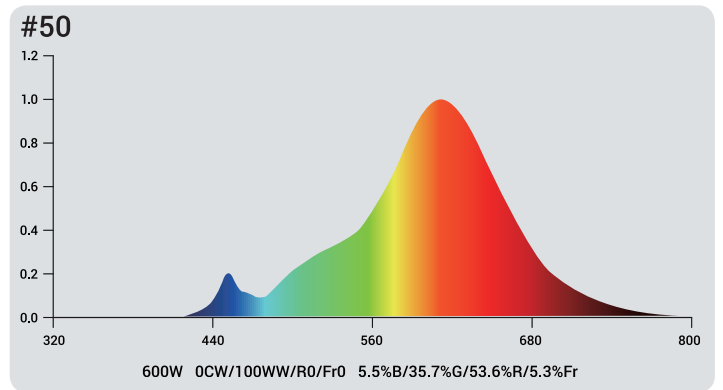
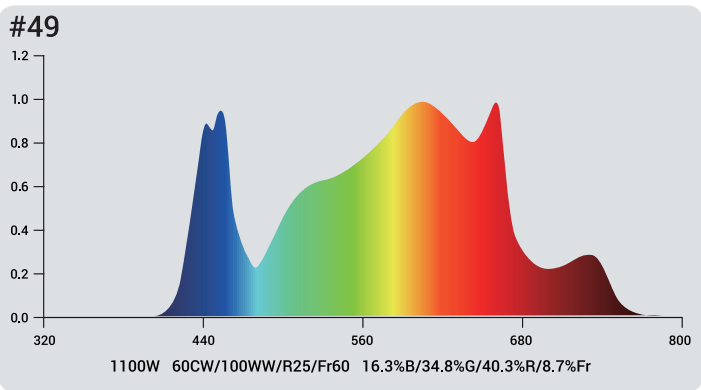
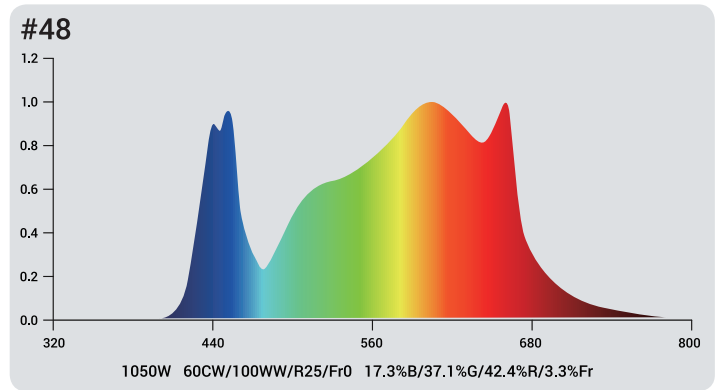
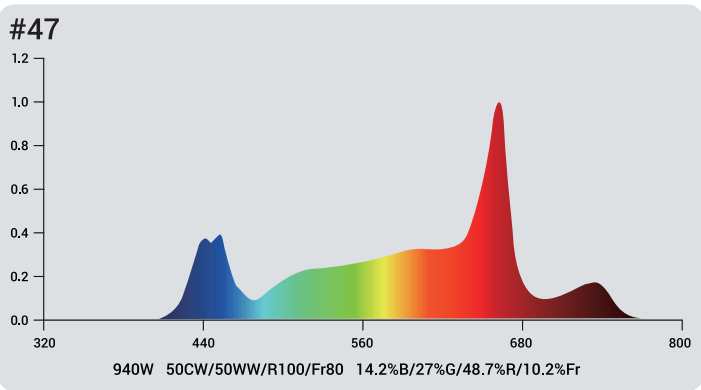
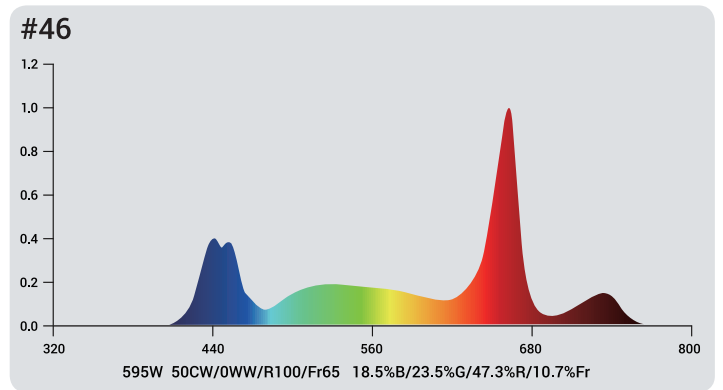
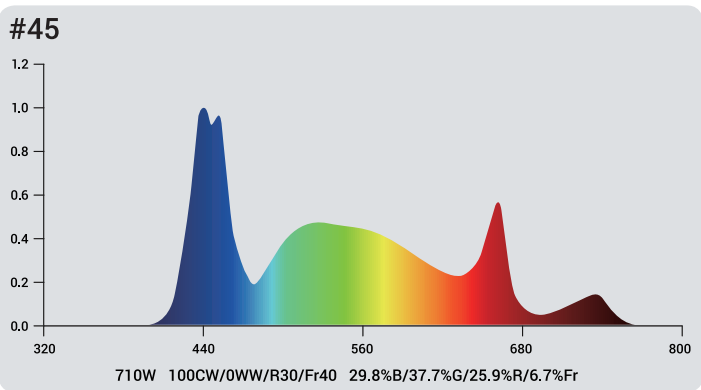
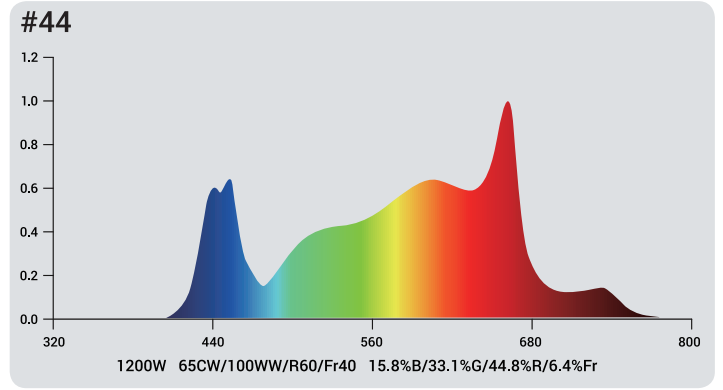
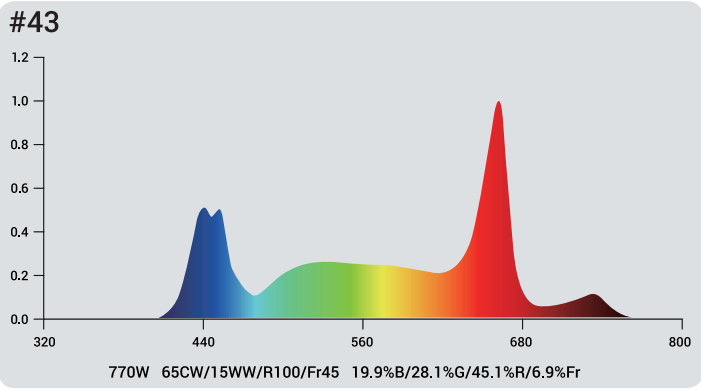
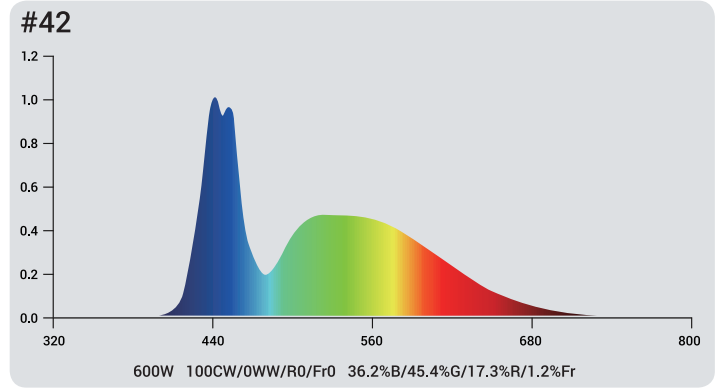
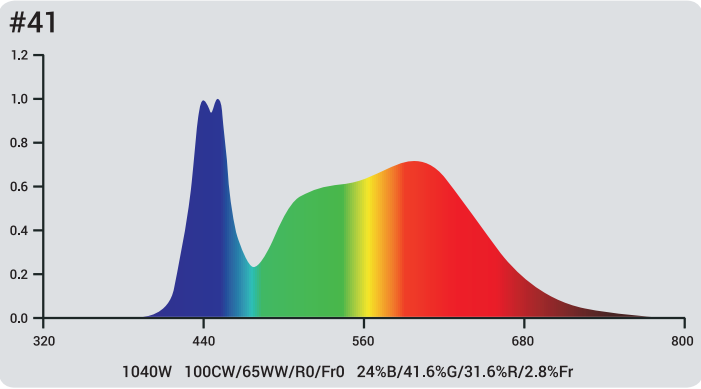

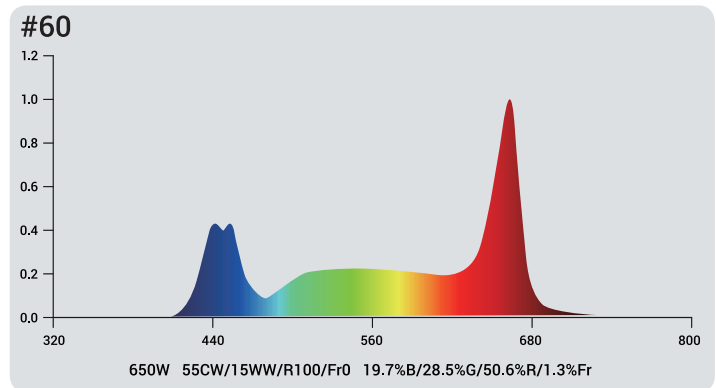
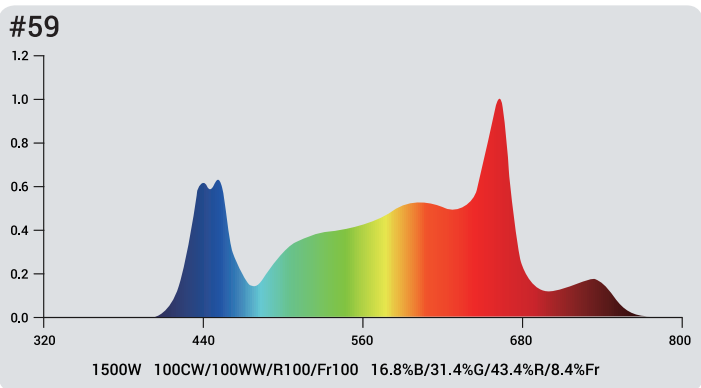
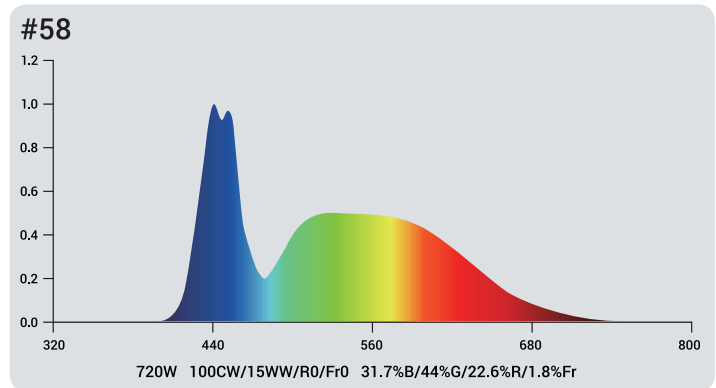
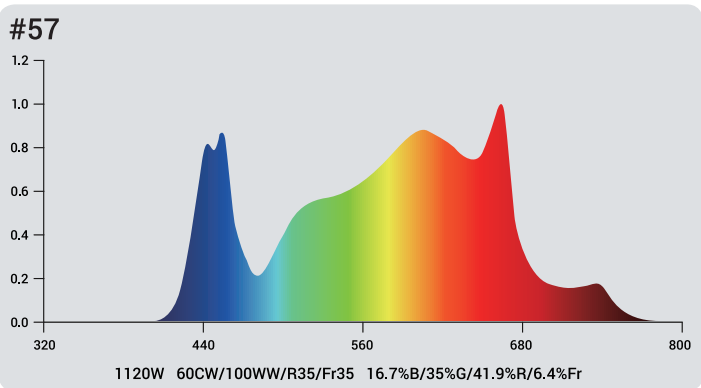
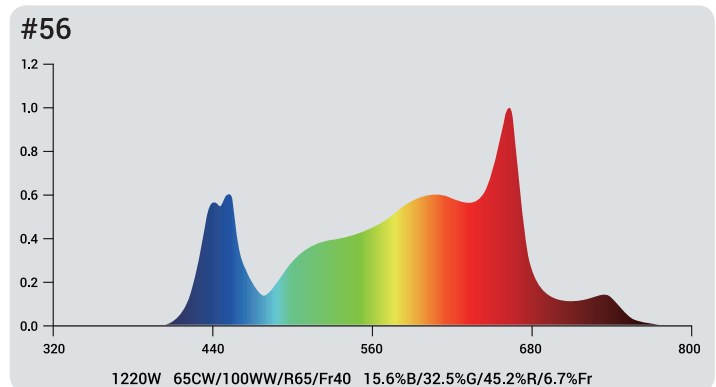
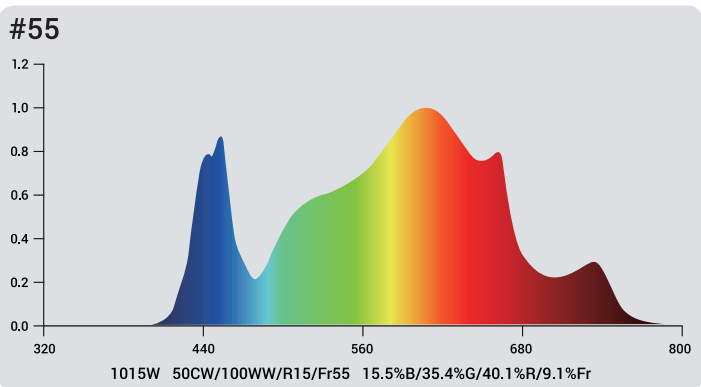
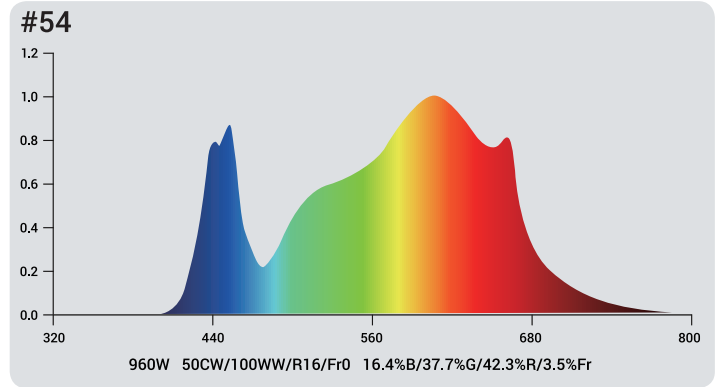
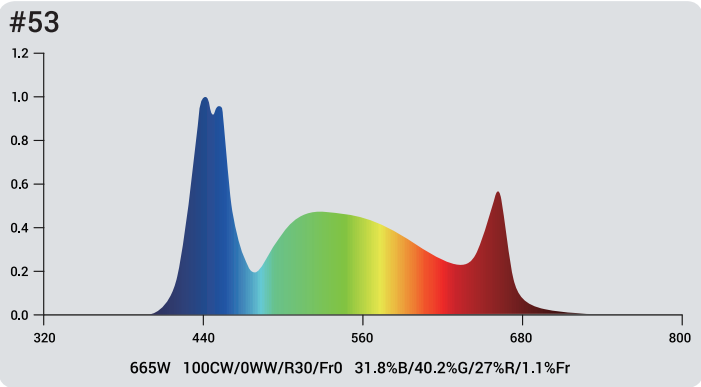
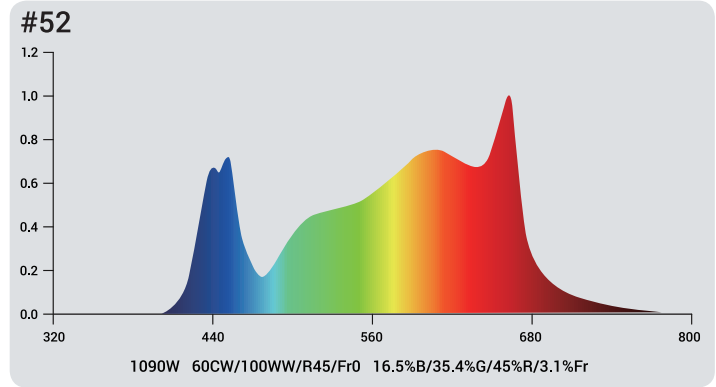
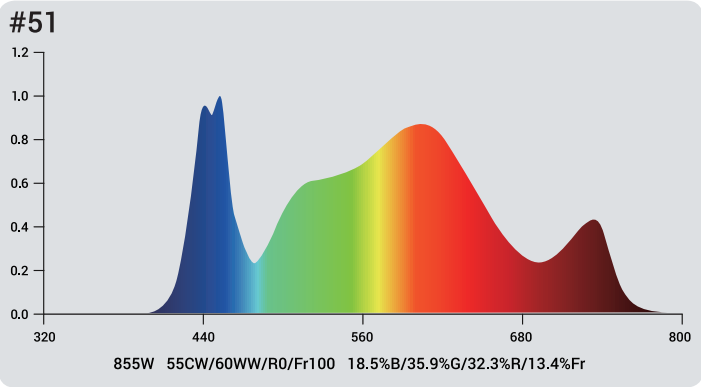

Spectrum Number	Corresponding GML Model Name
#6	Master 6V; Master 4V
#15	Tarantula Booster 660nm Bar
#16	Tarantula Booster 730nm Bar
#48	Tarantula Long Leg (2nd channel off)
#49	Tarantula Long Leg (all channels at 100%)
#50	Tarantula Booster 2200K Bar
#51	Tarantula Leafy Green Bar
#52	Master 6B; Tarantula Veggie Bar
#53	Tarantula Reproduction Bar
#54	Tarantula Vulcan Nitro (2nd channel off)
#55	Tarantula Vulcan Nitro (all channels at 100%)
#56	Master 6 Bloom Red; Master 320R; Master 150R
#57	Tarantula Tent Ultimate; Tarantula Torch 730; Tarantula Torch 480; Tarantula Torch 320
#58	Tarantula Booster 8000K Bar
#59	Tarantula Borg (all channels at 100%)
#60	Tarantula Greenhouse

Safety Warnings and Recommendations

Warning! Carefully read the warnings below before using or working with the product!

Always adhere to the local rules and regulations when installing or using the LED fixture.

Do not open or disassemble the LED fixture, it contains no serviceable parts inside. Opening or modifying the LED fixture can be dangerous and will void the warranty.

Wearing protective gloves and glasses is recommended during installation.

Do not use the LED fixture when either the LED fixture has been dropped or is damaged or its power cord is damaged.

Replace the power cord only with original certified cords. Keep the power cord away from hot surfaces.

Modifications to the cords can lead to unwanted electromagnetic effects, which makes the product not comply with legal requirements.

Do not plug the LED fixture into a supply voltage other than what is instructed on the fixture.

Always disconnect the LED fixture from mains before performing any maintenance.

The LED lighting product is extremely bright. Do not stare directly into any of the lights.

The LED fixture will get hot during operation. Do not touch when the light is on. Keep the LED fixture away from children.

Always allow for a cool down period of at least 30 min. before touching the LED rails. Touching the LED rails when the fixture is lit or immediately afterwards can result in severe burns!

Do not expose the LED fixture to:
(ambient) temperatures outside the specified range;
dust and contamination;
direct sunlight during use or HID light that could heat up the ballast.

Do not use the LED fixture near flammable, explosive or reactive substances. Do not use sulfur vaporizers or water misters.

The installation and use of the LED fixture are the responsibility of the end user. Incorrect use or installation can lead to failure and damage to the LED fixture. Damage to the LED fixture and electronic circuitry because of incorrect installation and use will void the warranty.

Installation Instruction

1

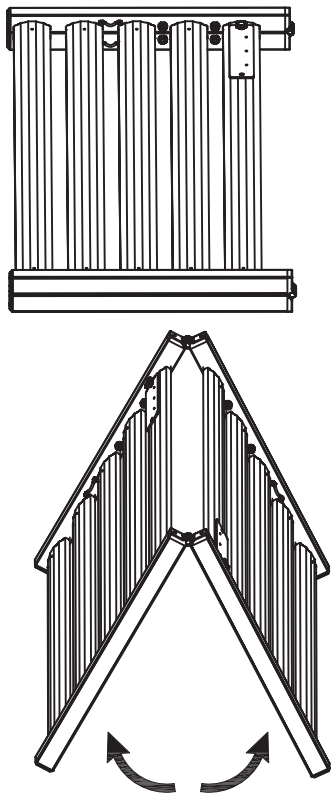

Unfold the LED fixture.

2

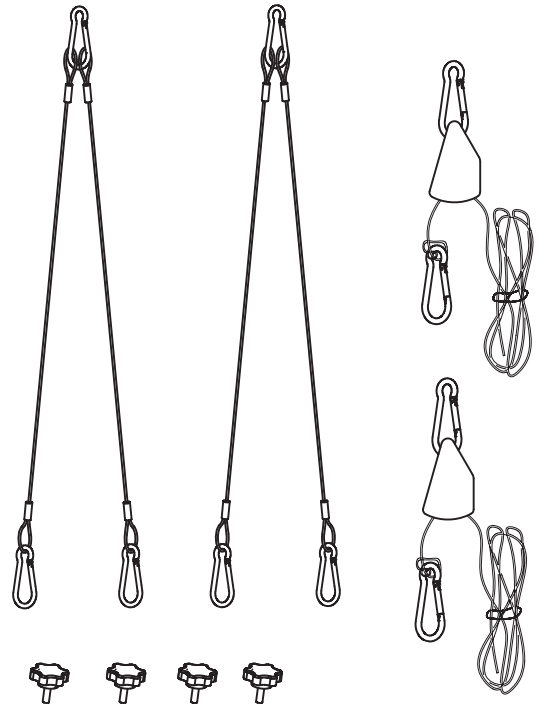

Take out the accessories from their bags.

3

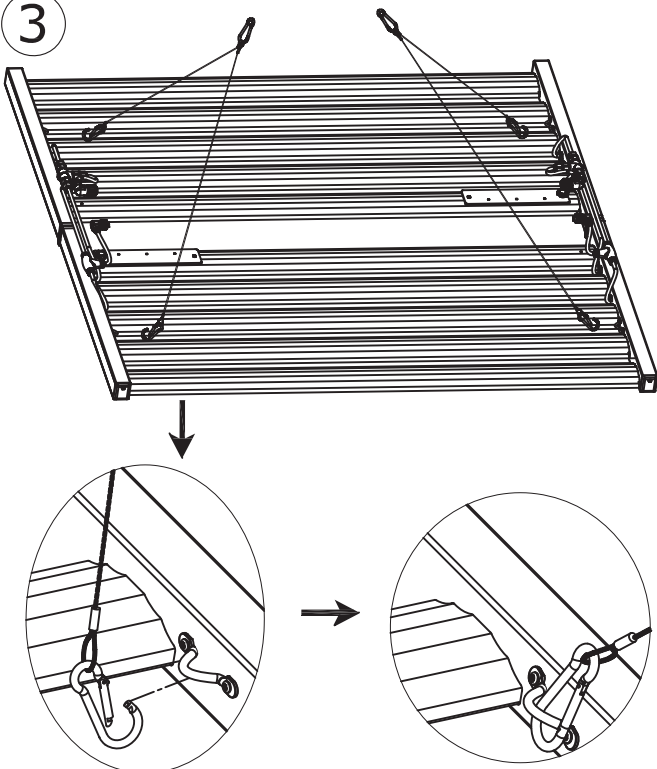

Connect carabiner hooks with mounting rings (on fixture frame).

4

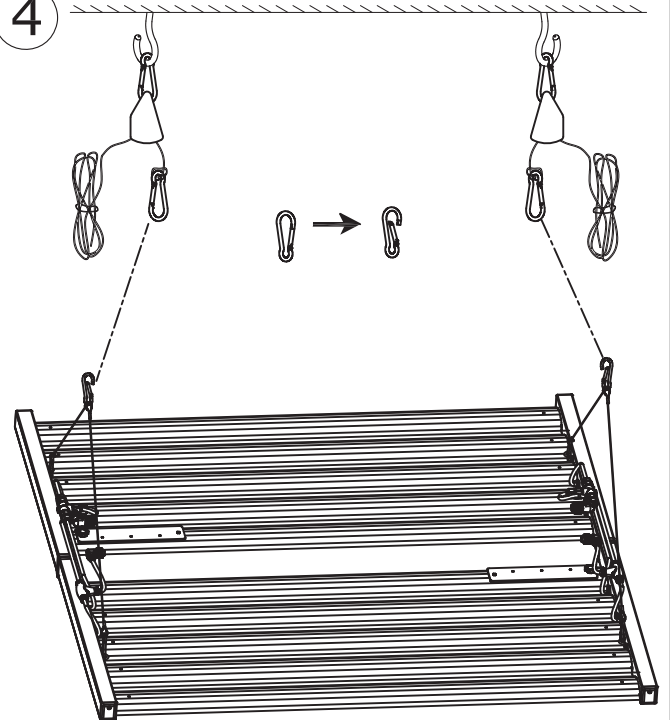

Attach steel ropes to adjustable ratchet hangers.

