

// RESIDENTIAL RANGE

MINITUBE

IN-LINE DUCT MOUNTED FAN



The Minitube Series of duct mounted axial fans are suitable for exhausting or supplying air in domestic and commercial applications such as bathrooms, toilets, ensuites and apartments.

- Includes robust mounting feet.
- Light-weight but robust aluminium fan housing with plastic spigots.
- Axial impellers made from plastic.
- Matches 150mm standard duct size.
- Can be mounted in any position.
- Comes with plug and lead.

ACCESSORIES

- Flexible Duct - Fire Rated AS/NZS 4254.
- Backdraft Dampers.
- Internal and external grilles.



DIMENSIONS

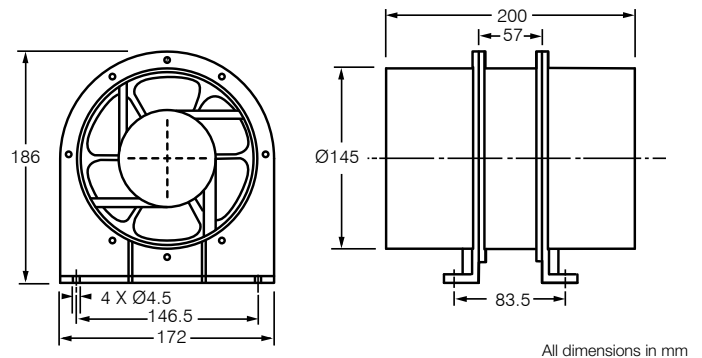

SPECIFICATIONS

MODEL NO.	M ³ /HR [†]	L/SEC [†]	AVG. dB(A) @ 3M	INPUT POWER	POWER SUPPLY	AMPS	VOLTS
MTP132	310	86	45	28W	50-60Hz	0.14	220-240

[†] Air flow without duct and fittings

*Conditions apply. For details visit: fantechtrade.com.au/warranty